

Installation Guide

M9045B, M9048A, M9048B, M9049A

Keysight Remote PC PCIe Host Desktop Adapter Modules



Notices

© Keysight Technologies, Inc. 2015

No part of this manual may be reproduced in any form or by any means (including electronic storage and retrieval or translation into a foreign language) without prior agreement and written consent from Keysight Technologies, Inc. as governed by United States and international copyright laws.

Manual Part Number

M9049-90001

Edition

First Edition, June 2015

Printed in

Malaysia

Published by

Keysight Technologies, Inc.
900 S. Taft Ave.
Loveland, CO 80537 USA

Trademarks

PICMG[®], Compact PCI[®] are registered trademarks of the PCI Industrial Computer Manufacturers Group.

AdvancedTCA[®] and ATCA are registered trademarks of the PCI Industrial Computer Manufacturers Group.

PCI-SIG[®], PCI Express[®], and PCIe[®] are registered trademarks of PCI-SIG.

Technology Licenses

The hardware and/or software described in this document are furnished under a license and may be used or copied only in accordance with the terms of such license.

Declaration of Conformity

Declarations of Conformity for this product and for other Keysight products may be downloaded from the Web. Go to <http://keysight.com/go/conformity>. You can then search by product number to find the latest Declaration of Conformity.

U.S. Government Rights

The Software is “commercial computer software,” as defined by Federal Acquisition Regulation (“FAR”) 2.101. Pursuant to FAR 12.212 and 27.405-3 and Department of Defense FAR Supplement (“DFARS”) 227.7202, the U.S. government acquires commercial computer software under the same terms by which the software is customarily provided to the public. Accordingly, Keysight provides the Software to U.S. government customers under its standard commercial license, which is embodied in its End User License Agreement (EULA), a copy of which can be found at <http://www.keysight.com/find/sweula>. The license set forth in the EULA represents the exclusive authority by which the U.S. government may use, modify, distribute, or disclose the Software. The EULA and the license set forth therein, does not require or permit, among other things, that Keysight: (1) Furnish technical information related to commercial computer software or commercial computer software documentation that is not customarily provided to the public; or (2) Relinquish to, or otherwise provide, the government rights in excess of these rights customarily provided to the public to use, modify, reproduce, release, perform, display, or disclose commercial computer software or commercial computer software documentation. No additional government requirements beyond those set forth in the EULA shall apply, except to the extent that those terms, rights, or licenses are explicitly required from all providers of commercial computer software pursuant to the FAR and the DFARS and are set forth specifically in writing elsewhere in the EULA. Keysight shall be under no obligation to update, revise or otherwise modify the Software. With respect to any technical data as defined by FAR 2.101, pursuant to FAR 12.211 and 27.404.2 and DFARS 227.7102, the U.S. government acquires no greater than Limited Rights as defined in FAR 27.401 or DFARS 227.7103-5 (c), as applicable in any technical data.

Warranty

THE MATERIAL CONTAINED IN THIS DOCUMENT IS PROVIDED “AS IS,” AND IS SUBJECT TO BEING CHANGED, WITHOUT NOTICE, IN FUTURE EDITIONS. FURTHER, TO THE MAXIMUM EXTENT PERMITTED BY APPLICABLE LAW, KEYSIGHT DISCLAIMS ALL WARRANTIES, EITHER EXPRESS OR IMPLIED, WITH REGARD TO THIS MANUAL AND ANY INFORMATION CONTAINED HEREIN, INCLUDING BUT NOT LIMITED TO THE IMPLIED WARRANTIES OF MERCHANTABILITY AND FITNESS FOR A PARTICULAR PURPOSE. KEYSIGHT SHALL NOT BE LIABLE FOR ERRORS OR FOR INCIDENTAL OR CONSEQUENTIAL DAMAGES IN CONNECTION WITH THE FURNISHING, USE, OR PERFORMANCE OF THIS DOCUMENT OR OF ANY INFORMATION CONTAINED HEREIN. SHOULD KEYSIGHT AND THE USER HAVE A SEPARATE WRITTEN AGREEMENT WITH WARRANTY TERMS COVERING THE MATERIAL IN THIS DOCUMENT THAT CONFLICT WITH THESE TERMS, THE WARRANTY TERMS IN THE SEPARATE AGREEMENT SHALL CONTROL.

Keysight Technologies does not warrant third-party system-level (combination of chassis, controllers, modules, etc.) performance, safety, or regulatory compliance unless specifically stated.

Safety Information

CAUTION

A CAUTION denotes a hazard. It calls attention to an operating procedure or practice that, if not correctly performed or adhered to, could result in damage to the product or loss of important data. Do not proceed beyond a CAUTION notice until the indicated conditions are fully understood and met.

WARNING

A WARNING denotes a hazard. It calls attention to an operating procedure or practice, that, if not correctly performed or adhered to, could result in personal injury or death. Do not proceed beyond a WARNING notice until the indicated conditions are fully understood and met.

Safety Information

The following general safety precautions must be observed during all phases of operation of this instrument. Failure to comply with these precautions or with specific warnings or operating instructions in the product manuals violates safety standards of design, manufacture, and intended use of the instrument. Keysight Technologies assumes no liability for the customer's failure to comply with these requirements.

General

Do not use this product in any manner not specified by the manufacturer. The protective features of this product must not be impaired if it is used in a manner specified in the operation instructions.

Before Applying Power

Verify that all safety precautions are taken. Make all connections to the unit before applying power. Note the external markings described under "Safety Symbols".

Ground the Instrument

Keysight chassis are provided with a grounding-type power plug. The instrument chassis and cover must be connected to an electrical ground to minimize shock hazard. The ground pin must be firmly connected to an electrical ground (safety ground) terminal at the power outlet. Any interruption of the protective (grounding) conductor or disconnection of the protective earth terminal will cause a potential shock hazard that could result in personal injury.

Do Not Operate in an Explosive Atmosphere

Do not operate the module/chassis in the presence of flammable gases or fumes.

Do Not Operate Near Flammable Liquids

Do not operate the module/chassis in the presence of flammable liquids or near containers of such liquids.

Cleaning

Clean the outside of the Keysight module/chassis with a soft, lint-free, slightly dampened cloth. Do not use detergent or chemical solvents.

Do Not Remove Instrument Cover

Only qualified, service-trained personnel who are aware of the hazards involved should remove instrument covers. Always disconnect the power cable and any external circuits before removing the instrument cover.

Keep Away From Live Circuits

Operating personnel must not remove equipment covers or shields. Procedures involving the removal of covers and shields are for use by service-trained personnel only. Under certain conditions, dangerous voltages may exist even with the equipment switched off. To avoid dangerous electrical shock, DO NOT perform procedures involving cover or shield removal unless you are qualified to do so.

Do Not Operate Damaged Equipment

Whenever it is possible that the safety protection features built into this product have been impaired, either through physical damage, excessive moisture, or any other reason, REMOVE POWER and do not use the product until safe operation can be verified by service-trained personnel. If necessary, return the product to an Keysight Technologies Sales and Service Office for service and repair to ensure the safety features are maintained.

Do Not Block The Primary Disconnect

The primary disconnect device is the appliance connector/power cord when a chassis used by itself, but when installed into a rack or system the disconnect may be impaired and must be considered part of the installation.

Do Not Modify the Instrument

Do not install substitute parts or perform any unauthorized modification to the product. Return the product to an Keysight Sales and Service Office to ensure that safety features are maintained.

In Case of Damage

Instruments that appear damaged or defective should be made inoperative and secured against unintended operation until they can be repaired by qualified service personnel.

CAUTION

Do NOT block vents and fan exhaust: To ensure adequate cooling and ventilation, leave a gap of at least 50mm (2") around vent holes on both sides of the chassis.

Do NOT operate with empty slots: To ensure proper cooling and avoid damaging equipment, fill each empty slot with an AXle filler panel module.

Do NOT stack free-standing chassis: Stacked chassis should be rack-mounted.

All modules are grounded through the chassis: During installation, tighten each module's retaining screws to secure the module to the chassis and to make the ground connection.

WARNING

Operator is responsible to maintain safe operating conditions. To ensure safe operating conditions, modules should not be operated beyond the full temperature range specified in the Environmental and physical specification. Exceeding safe operating conditions can result in shorter lifespan, improper module performance and user safety issues. When the modules are in use and operation within the specified full temperature range is not maintained, module surface temperatures may exceed safe handling conditions which can cause discomfort or burns if touched. In the event of a module exceeding the full temperature range, always allow the module to cool before touching or removing modules from the chassis.

Safety Symbols

Products display the following symbols:



Refer to manual for additional safety information.



Earth Ground.



Chassis Ground.



Alternating Current (AC).



Direct Current (DC).



Standby Power. Unit is not completely disconnected from AC mains when power switch is in standby position



Indicates that antistatic precautions should be taken.



Operate the PXIe chassis in the horizontal orientation. Do NOT operate this chassis in the vertical orientation.



The CSA mark is a registered trademark of the Canadian Standards Association and indicates compliance to the standards laid out by them. Refer to the product Declaration of Conformity for details.



Notice for European Community: This product complies with the relevant European legal Directives: EMC Directive (2004/108/EC) and Low Voltage Directive (2006/95/EC).



The Regulatory Compliance Mark (RCM) mark is a registered trademark. This signifies compliance with the Australia EMC Framework regulations under the terms of the Radio Communication Act of 1992.

ICES/NMB-001

ICES/NMB-001 indicates that this ISM device complies with the Canadian ICES-001.



This symbol represents the time period during which no hazardous or toxic substance elements are expected to leak or deteriorate during normal use. Forty years is the expected useful life of this product.



South Korean Class A EMC Declaration. this equipment is Class A suitable for professional use and is for use in electromagnetic environments outside of the home.

A 급 기기 (업무용 방송통신기자재)
이 기기는 업무용 (A 급) 전자파적합기
기로서 판 매자 또는 사용자는 이 점을 주
의하시기 바라 며 , 가정외의 지역에서
사용하는 것을 목적으로 합니다.



Waste Electrical and Electronic Equipment (WEEE) Directive 2002/96/EC

This product complies with the WEEE Directive (2002/96/EC) marking requirement. The affixed product label (see below) indicates that you must not discard this electrical/electronic product in domestic household waste.

Product Category: With reference to the equipment types in the WEEE directive Annex 1, this product is classified as a "Monitoring and Control instrumentation" product.

Do not dispose in domestic household waste.

To return unwanted products, contact your local Keysight office for more information.



Contents

Introduction	9
Step 1: Unpack and Inspect the Module	10
ESD	10
Inspect for damage	10
If you need to return the module	11
Step 2: Verify Shipment Contents	12
Step 3: Install the Host Adapter in the Host PC	13
M9045B PCIe ExpressCard Adapter Installation	13
M9048A/B Installation	15
M9048A LEDs	16
M9048B LEDs	16
M9048A switch settings	17
M9048B switch settings	18
M9049A Installation	19
LEDs	20
Switches	20
Connecting a PC to a PXIe or AXIe Chassis	23
External PC to a single chassis configuration	23
External PC to two chassis configuration	24
External PC, x16 connection to single PXIe chassis configuration	25
Module Characteristics	26
Related Products	26
Troubleshooting and Service	27

Introduction

The M9045B, M9048A, M9048B, and M9049A PCIe Host Desktop Adapter modules provide a cabled PCIe link between a PXIe or AXIe chassis and an external host computer. The host desktop adapter cards plug into your remote computer's PCIe slot to provide a high performance link between the computer and a PXIe or AXIe chassis. The M9048A/B and M9049A host adapters include PCIe switch and clock isolation for a high-quality clock source driven down the PCIe cable to the PXIe or AXIe chassis for a consistent Gen 2 or Gen 3 link independent of the remote computer. The cards are compatible with desktop or rack-mount computers with either x8 or x16 PCIe expansion slots (mechanical). Use the Y1202A 2-meter or Y1203A 0.5 meter cables to connect the host adapter cards to any PXIe chassis with a system module or AXIe chassis.

The modules provide the following features:

M9045B PCIe ExpressCard Adapter, Gen 1, x1 speed.

NOTE

The Keysight M9045B is supported only in Gen1 ExpressCard slots. If your PC has Gen2 slots, you may be able to reconfigure them to Gen 1 in the PC's BIOS.

M9048A Single Port PCIe Host Adapter, x8 Gen2 only, 5 GB/s

M9048B Single Port PCIe Host Adapter, x8 up to Gen3, 8 GB/s (Gen3 x8 PC slot)

M9049A Dual Port PCIe Host Adapter, x8 or x16, up to Gen3, 8 GB/s to 16 GB/s (Gen3 x16 PC slot)

You don't need to install software drivers to use these Host Desktop Adapters modules; the software is already included in the Windows OS.

The M9048B and M9049A are high performance. They run at Gen3 speeds and should only be used with Windows 7 SP1 64bit and Windows 8.1 Update1 64bit.

Step 1: Unpack and Inspect the Module

CAUTION

Keysight's PXIe Modules are shipped in materials that prevent static electricity damage. The modules should only be removed from the packaging in an anti-static area ensuring that correct anti-static precautions are taken. Store all modules in anti-static envelopes when not in use.

ESD

Electrostatic discharge (ESD) can damage or destroy electronic components. All work on electronic assemblies should be performed at a static-safe work station. The following figure shows an example of a static-safe work station using two types of ESD protection. Purchase acceptable ESD accessories from your local supplier.

- Conductive table-mat and wrist-strap combination.
- Conductive floor-mat and heel-strap combination.

Both types, when used together, provide a significant level of ESD protection. Of the two, only the table-mat and wrist-strap combination provides adequate ESD protection when used alone. To ensure user safety, the static-safe accessories must provide at least $1\text{ M}\Omega$ of isolation from ground.

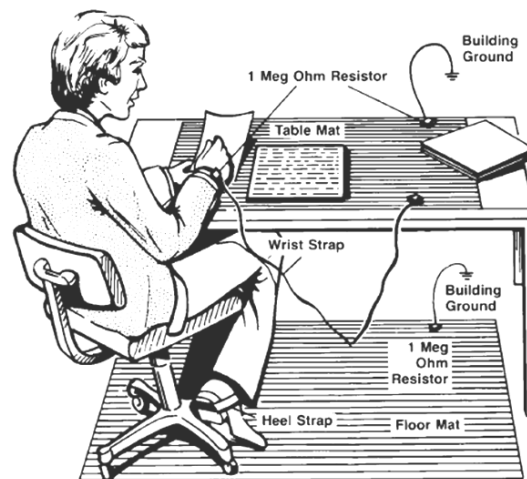

Inspect for damage

After unpacking the module, carefully inspect it for any shipping damage. Report any damage to the shipping agent immediately, as such damage is not covered by the warranty.

CAUTION

To avoid damage when handling a module; do not touch exposed connector pins.

Step 1: Unpack and Inspect the Module

- 1 After unpacking the module, verify that all items listed on the packing list are included.
- 2 Inspect the module for shipping damage.
- 3 Save all packing material for storage or return shipment to Keysight.

If you need to return the module

Should it become necessary to return a Keysight module for repair or service, follow the steps below:

- 1 Review the warranty information shipped with your product.
- 2 Contact Keysight to obtain a return authorization and return address. If you need assistance finding Keysight contact information go to www.keysight.com/find/assist (worldwide contact information for repair and service) or refer to the **Support** information on the product web page, for example: www.keysight.com/find/M9045B.
- 3 Write the following information on a tag and attach it to the malfunctioning equipment.
 - Name and address of owner. A Post Office box is not acceptable as a return address.
 - Product model number (for example, M9045B)
 - Product serial number (for example, TWXXXXXXXX). The serial number label is located on the side of the module.
 - A description of failure or service required.
- 4 Carefully pack the module in its original ESD bag and carton. If the original carton is not available, use bubble wrap or packing peanuts, place the instrument in a sealed container and mark the container "FRAGILE".
- 5 On the shipping label, write ATTENTION REPAIR DEPARTMENT and the service order number (if known).

NOTE

If any correspondence is required, refer to the product by model number and serial number.

Step 2: Verify Shipment Contents

Your shipment should have included the following:

- The Keysight M904x module that you ordered.
- Keysight Product Software and Information CD.

NOTE

The most current version of Keysight IO Libraries is required prior to installing and running any other software. The latest version can be downloaded from: www.keysight.com/find/iosuite.

No other drivers are required to operate the PCIe Host Adapter modules. However, your application modules may require drivers.

Step 3: Install the Host Adapter in the Host PC

The Keysight Host Adapter modules have been designed for easy installation. However, the following standard precautions, installation procedures, and general information must be observed to ensure proper installation and to prevent damage to the board, other system components, or injury to personnel.

M9045B PCIe ExpressCard Adapter Installation

The M9045B is a PCIe x1 interface card in the ExpressCard 34 format. It provides Gen 1 x1 PCIe Express expansion capabilities to laptop computers. The adapter provides PCIe x1 connectivity to different lane-width devices such as the x8 connector on the Keysight M9502A or M9505A AXIe chassis or the Keysight M9021A PXIe System Interface Module in an M9018A PXIe chassis through a x1 to x8 cable. It uses an x1 connector and should be used with x1 to x8 cables such as the Keysight Y1200B. Operation is transparent to the software application and no software drivers are required.

NOTE

The Keysight M9045B is supported only in Gen1 ExpressCard slots. If your PC has Gen2 slots, you may be able to reconfigure them to Gen 1 in the PC's BIOS.



Figure 1 Keysight M9045B PCIe ExpressCard Adapter

- 1 Turn off the host PC and the remote chassis.
- 2 Choose an empty ExpressCard slot on your PC. The adapter may be installed in any ExpressCard 34 (single wide). An ExpressCard 54 (double wide) slot may also be used. Check with PC manufacturer's documentation. Some PCs require you to remove a plastic cover or filler plate.
- 3 Remove the M9045B Adapter from its protective bag. Observe Electrostatic Discharge precautions.

NOTE

If you are using the M9045B ExpressCard Adapter in an ExpressCard 54 slot, you may need to attach the plastic alignment spacer to the side of the adapter.

- 4 Install the adapter into an ExpressCard slot on your PC.
- 5 Attach the x1 end of the Y1200B PCIe cable to the adapter and hand-tighten the thumbscrews.
- 6 Attach the x8 end of the cable to the x8 connector on the system module or the interface installed in the Keysight PXle or AXle chassis. Pull back on the retractor ring. With the keyed slot aligned with the key ridge on the PCIe adapter, insert the cable connector into the x8 connector until the cable locks in place.

NOTE

If you are using a remote controller, you must power up the chassis BEFORE you power up the PC. When you power down your system, shut down the PC BEFORE you power down the chassis.

- 7 Power up the PXle chassis. Verify that the chassis fans are operating and free of obstructions that may restrict air flow.

Step 3: Install the Host Adapter in the Host PC

M9048A/B Installation

- 1 Turn off both the host PC and the AXIe or PXIe chassis. Make certain that the AC line power is removed from the host PC or the PC may awaken unexpectedly.
- 2 Open the PC (remove the PC cover) according to the manufacturer's instructions.
- 3 Remove the M9048A/B Adapter from its protective bag. Observe normal Electrostatic Discharge (ESD) precautions.

NOTE

Keysight's M9048A comes with a standard PCIe faceplate preinstalled. If you need to replace the faceplate with the low profile faceplate, carefully remove the two mounting screws to remove the faceplate. Use the two screws to mount the low profile faceplate. Securely tighten but do not over tighten the two screws.

- 4 Install the adapter into a PCIe x8 or x16 card slot in the PC. The module is a x8 module; no additional performance is obtained using a x16 slot in the PC. Ensure that the card is seated properly and tighten the PC chassis screw.
- 5 Reinstall the cover on your PC.
- 6 Attach a PCIe x8 cable by first pulling back on the retractor ring. With the keyed slot aligned with the key ridge on the adapter, insert the cable connector into the cable port connector on the adapter until the cable locks in place.

NOTE

The connectors on either end of the PCIe x8 cable are identical. Each connector has a retractor to allow the connector to lock in place.

- 7 Attach the other end of the cable to the upstream port on the system controller module in the Keysight PXIe or AXIe chassis. Computer cables should always use strain relief to protect the connected equipment.
- 8 Turn on the Chassis, wait until the chassis is ready, then power on the PC. Refer to your chassis manuals for the LED ready indication.

M9048A LEDs

LED name	LED Off	LED Yellow	LED Green	LED Green & blinking
Link	Power off	Power on but link is not operational	Power on and link is operational	Power on, link is transmitting/receiving data
NTB	Normal operation	N/A	Error*	N/A

*Your switches are set wrong. Change them to a valid configuration.

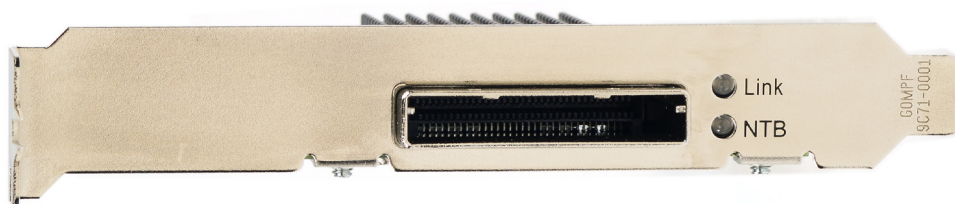

Figure 2 M9048A Front Panel

M9048B LEDs

LED	LED Indication			
Status (single color)	LED off. No link has been made	LED blinks at 0.5 Hz rate means Link in Gen 1 mode	LED blinks at 1.0 Hz rate means Link in Gen 2 mode	LED constant on means Link in Gen 3 mode
Host (bi-color)	LED off means no power applied	Orange LED means all power is okay.	Green LED means link partner established.	

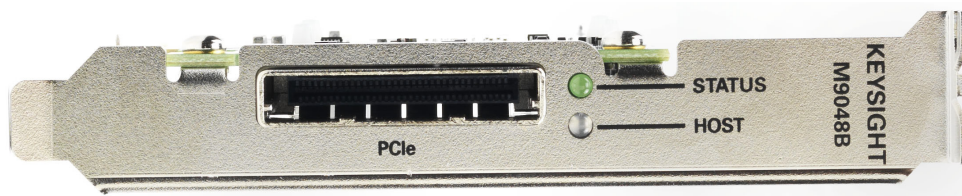

Figure 3 M9048B Front Panel

Step 3: Install the Host Adapter in the Host PC

M9048A switch settings

Keysight's M9048A has two banks of switches, SW1 and SW2. The default switch settings are shown in the graphic below. Make certain the switches on your module are set according to the picture below. These switches are for testing purposes or reserved for future use.

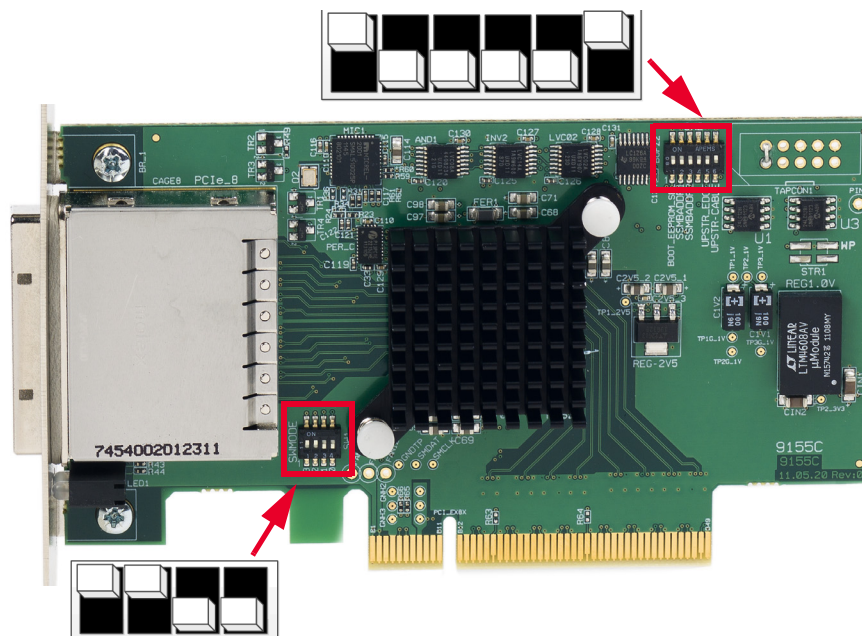

Figure 4 M9048A Default Switch Positions

NOTE

For SW1: The default setting (1100) is shown in the graphic. Switch settings 0001 are also acceptable for use with Keysight chassis. SW1 may be removed on future versions of the M9048A.

M9048B switch settings

Keysight's M9048B has one bank of switches labeled SW1. The default switch settings are shown below.

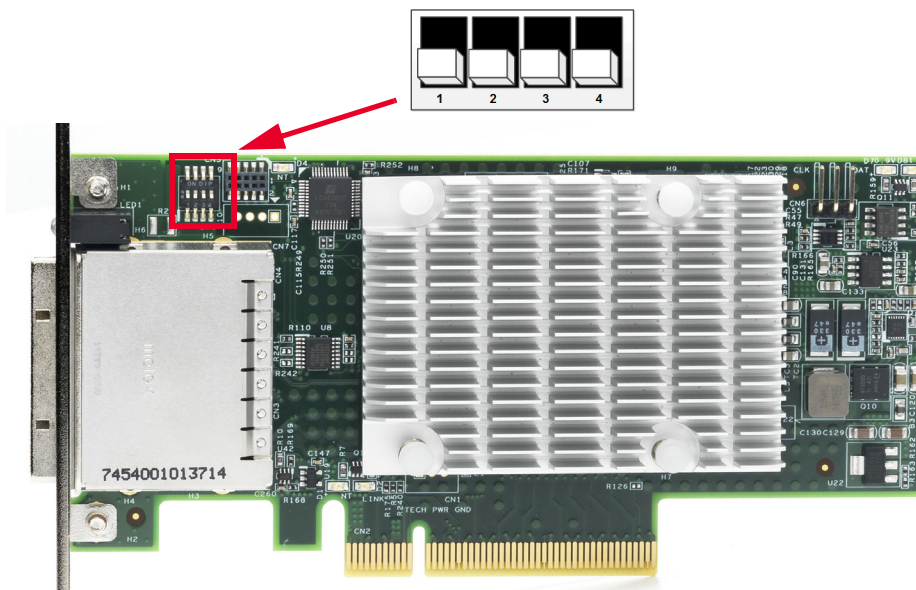

Figure 5 M9048B Default Switch Positions – All Off

Switch1 and Switch2 are reserved for Keysight testing or for future use. Do not move these switches

M9048B Switch Settings		
Switch3	Switch4	
Off	Off	Target Speed for both ports and the PCIe slot is Gen3. This is the default.
Off	On	Target Speed for both ports and the PCIe slot is Gen1
On	Off	Target Speed for both ports and the PCIe slot is Gen2
On	On	Target Speed for both ports and the PCIe slot is Gen3

The switch settings that set the target speed to a specific speed, allows you to force the link speed to train at a lower speed, which may be required with low performance PCs.

Step 3: Install the Host Adapter in the Host PC

M9049A Installation

- 1 Turn off both the host PC and the AXIe or PXIe chassis. Make certain that the AC line power is removed from the host PC or the PC may awaken unexpectedly.
- 2 Open the PC (remove the PC cover) according to the manufacturer's instructions.
- 3 Remove the M9049A Adapter from its protective bag. Observe normal Electrostatic Discharge (ESD) precautions.
- 4 Install the adapter into a PCIe x16 card slot in the PC. Ensure that the card is seated properly and tighten the PC chassis screw. Note that the module will operate normally in a x8 open back slot, but highest performance is obtained in a x16 slot.
- 5 Reinstall the cover on your PC.
- 6 Attach a PCIe x8 cable by first pulling back on the retractor ring. With the keyed slot aligned with the key ridge on the adapter, insert the cable connector into the cable port connector on the adapter until the cable locks in place.

NOTE

The connectors on either end of the PCIe x8 cable are identical. Each connector has a retractor to allow the connector to lock in place.

- 7 Attach the other end of the cable to the system controller module in the Keysight PXIe or AXIe chassis. Computer cables should always use strain relief to protect the connected equipment.
- 8 Turn on the Chassis, wait until the chassis is ready, then power on the PC. Refer to your chassis manuals for the LED ready indication.

LEDs

The M9049A module has four bi-colored LEDs (two for each port) visible through the faceplate. LED functions are as follows:

LED	LED Indication			
Status (single color)	LED off. No link has been made	LED blinks at 0.5 Hz rate means Link in Gen 1 mode	LED blinks at 1.0 Hz rate means Link in Gen 2 mode	LED constant on means Link in Gen 3 mode
Host (bi-color)	LED off means no power applied	Orange LED means all power is okay.	Green LED means link partner established.	

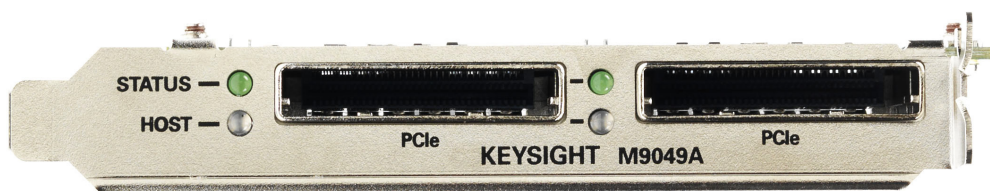

Figure 6 M9049A Front Panel

Switches

Keysight's M9049A has one bank of switches, SW1. The default switch settings are all OFF as shown in Figure 7. These switches set the mode of the two ports as well as the target speed as shown in the table below.

Step 3: Install the Host Adapter in the Host PC

M9049A Switch Settings*			
Switch1	Switch2	Switch3	Refer to Figure 7 for more explanation.
Off	Off	X	Sets Host Mode. This is the default switch setting. Host PC Connector Up Stream (US) Port 1 Down Stream (DS) Port 2 Down Stream (DS)
X	X	X	Reserved for Keysight Testing. Do not change these switch settings.
On	On	X	x16 Host Mode Host PC Connector (US) Combined for (DS) x16
Switch4		Switch5	
Off	Off	Target Speed for both ports and the PCIe slot is Gen3. This is the default.	
Off	On	Target Speed for both ports and the PCIe slot is Gen1	
On	Off	Target Speed for both ports and the PCIe slot is Gen2	
On	On	Target Speed for both ports and the PCIe slot is Gen3	
Switch6			
Not used			

* "X" means it does not matter which position the switch is in.
 US indicated Upstream connection
 DS indicated Downstream connection

Host Mode: In Default (Host mode), both Port 1 and Port 2 in the Downstream configuration. Th Host PC (the PC board edge connector) is the Upstream connection.

The switch settings that set the target speed to a specific speed, allow you to force the link speed to train at a lower speed, which may be required with low performance PCs.

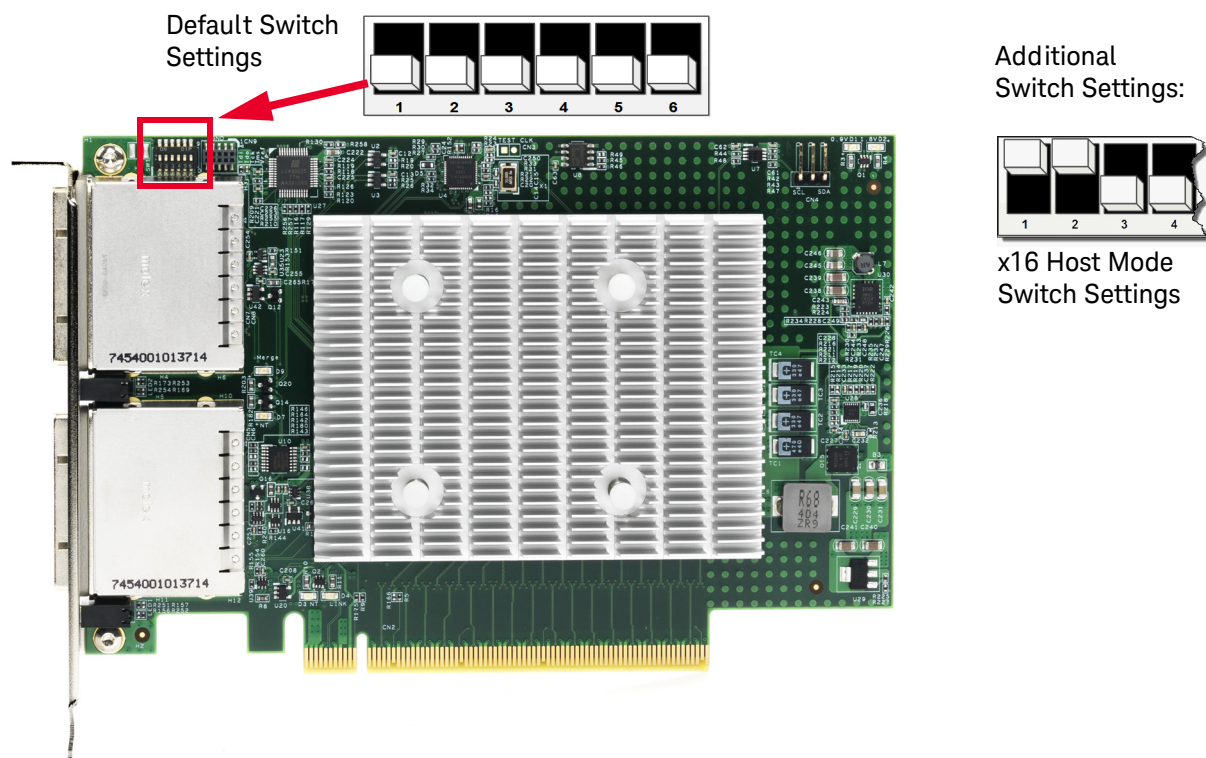

Figure 7 M9049A Default Switch Positions (all off)

The default switch positions allow you to connect the M9049A to 1 or 2 chassis each with an x8 connection.

The x16 Host mode switch setting allows you to connect the M9049A to a single chassis using two x8 PCIe cables at Gen 3 x16. The chassis must contain a dual port PXIe System module in the System Slot (slot1); use either an M9023A or M9024A. With the first x8 PCIe cable, plug one end of the cable to the top port of the M9049A and the other end of the cable to the top port of the PXIe System Module. With the second x8 PCIe cable, plug it into each of the bottom ports.

Connecting a PC to a PXIe or AXIe Chassis

The following examples show a few of the possible configurations between a PC (both PXIe embedded PC and an external PC) and a PXIe or AXIe chassis. Many other configurations are possible.

External PC to a single chassis configuration

The simplest system consists of a remote PC with a PCIe Host Adapter card (such as the Keysight M9048B) connected to a PXIe or AXIe chassis. A PXIe chassis requires a System Module or Cable Interface Module such as the Keysight M9021A. An AXIe chassis does not require a system module interface, because a cable port is included in the ESM half height module. This configuration has Gen 2 speed.

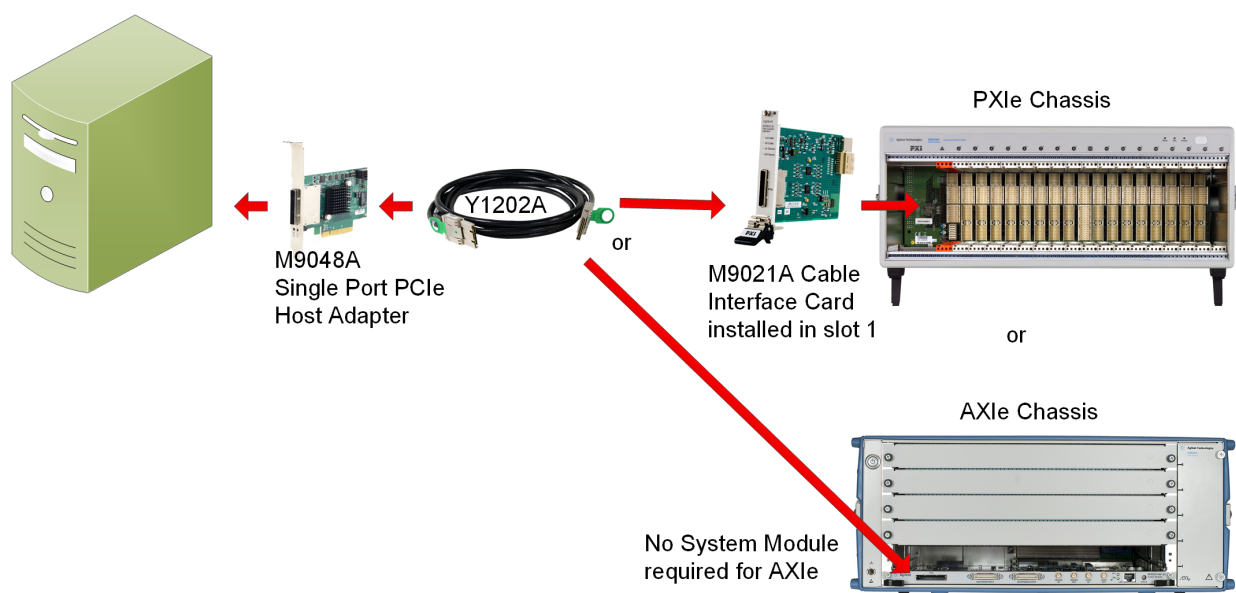

Figure 8 Basic external PC system configuration

External PC to two chassis configuration

Another simple system consists of a remote PC with a Dual Port PCIe Host Adapter card (such as the Keysight M9049A) connected to two PXIe or AXIe chassis. A PXIe chassis requires a System Module such as the Keysight M9022A. An AXIe chassis does not require a system module interface, because a cable port is included in the ESM half height module. The link speed is determined by the chassis; for example, Gen 2 speed with the M9018A PXIe chassis or the M9502A or M9505A AXIe chassis; Gen 3 speed may be available with Gen 3 PXIe chassis.

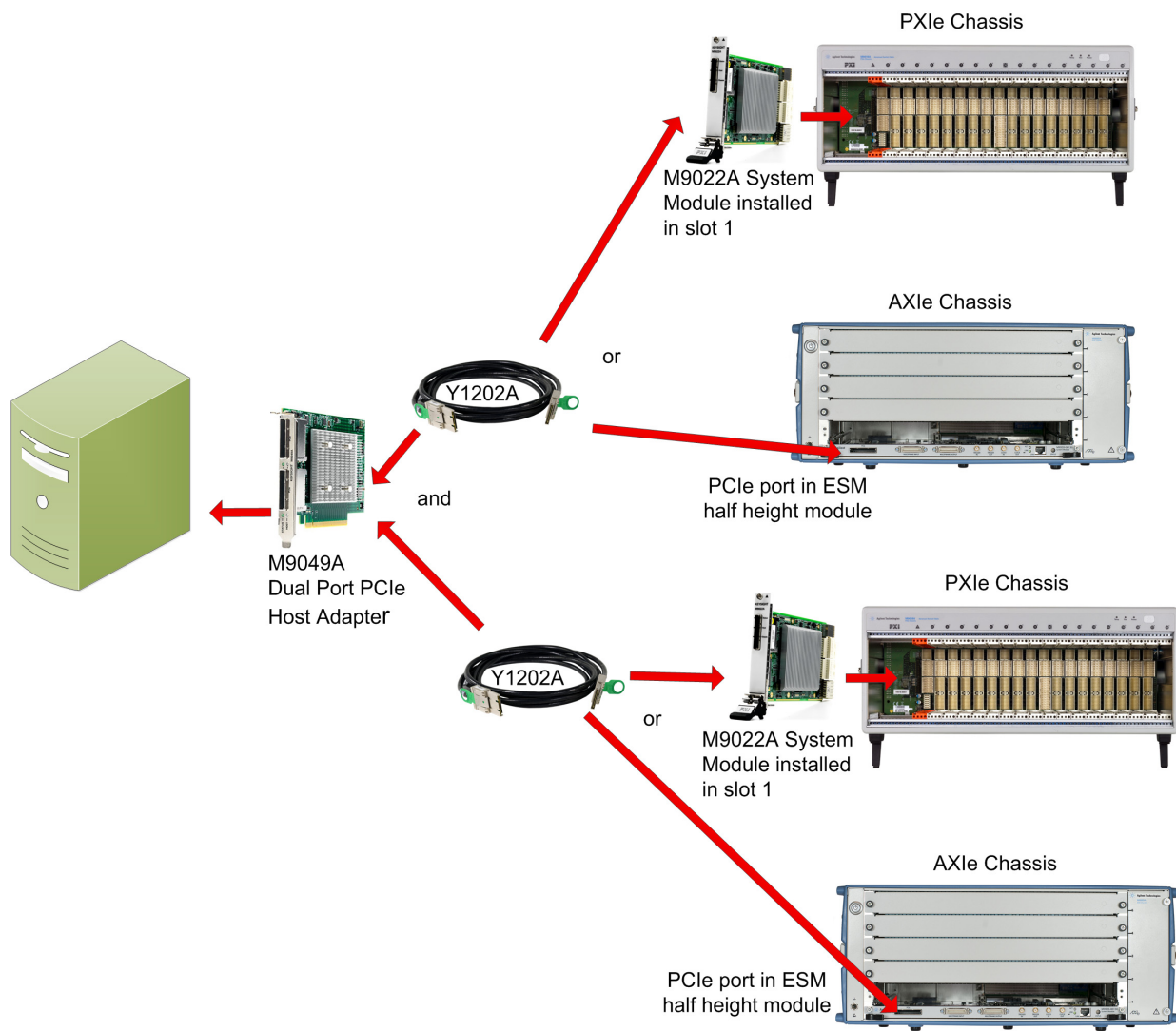

Figure 9 Simple two chassis configuration

External PC, x16 connection to single PXIe chassis configuration

The following configuration represents the fastest speed (x16) between the PC and the chassis. Make certain that all switches on the M9049A and the M9023A interface modules are set correctly to configure this operation.

Make certain the top connector on the M9049A module connects to the top connector on the M9023A module and the bottom connectors connect together.

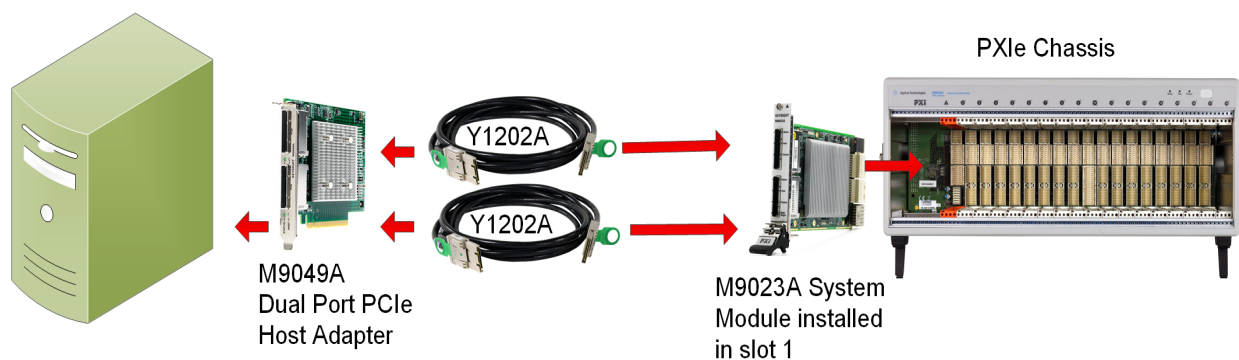

Figure 10 x16 Connection to the PXIe chassis

Module Characteristics

Hard ware	M9045B	M9048A	M9048B	M9049A
Card Format	PCIe Express Card 34	Low Profile	Low Profile	Standard Profile
Number of PCIe slots	1 Slot	1 Slot	1 Slot	1 Slot
Computer expansion slot compatibility	PCIe Express Card 34 or Express Card 54 with adapter	x8 Gen 2 or Gen 3*	x8 Gen 2 or Gen 3	x8 and x16, Gen 2 or Gen 3
Dimensions	34 mm (1.34 in) x 110.8 mm (4.36 in)	55 mm (2.2 in) x 114 mm (4.5 in)	56.15 mm (2.2 in) x 141 mm (5.5 in)	111.15 mm (4.4 in) x 167.65 mm (6.6 in)
Data bandwidth (max)	250 MB/s	4 GB/s (Gen 2, x8 PC slot)	8 GB/s (Gen3 x8 or x16 PC slot)	16 GB/s (Gen3 x8 or x16 PC slot)
Cable Connector(s)	one PCIe x1 iPass	One x8 PCIe iPass	One x8 PCIe iPass	Two x8 PCIe iPass
Card indicators	NA	LEDs for Link Status	LEDs for Link Status	LEDs for Link Status
Power consumption	3 W (typical)	7 W (typical)	7W (typical)	13 W (typical)
Cable Length	Up to 2-meter passive cable	Up to 2-meter passive cable	Up to 2-meter passive cable for PCIe Gen3**	Up to a 2-meter passive cable for PCIe Gen3**
Operating Temperature	0° C – 55° C	0° C – 55° C	0° C – 55° C	0° C – 55° C

* The M9048A is designed to be compatible with most Gen 3 PCIe computer slots but the link will train to Gen 2.

** Contact Keysight for information about longer optical cable support.

Related Products

Product	Description
M9021A	PCIe Cable Interface
M9022A	PXIe System Module: Single Port (x8), Gen 3
M9023A	PXIe High Performance System Module: Dual Port (x16) Gen 3
M9024A	PXIe High Performance System Module: Dual Port System Module with expanded connectivity: <ul style="list-style-type: none"> • Two 1Gb LAN Ports • Two USB 3.0 ports • Four USB 2.0 ports • GPIB
Y1200B	PCIe cable: x1 to x8, 2.0m (use with M9045B only)
Y1202A	PCIe cable: x8, 2.0m
Y1203A	PCIe cable: x8, 0.5m, used for chassis-to-chassis in multiple chassis systems

Troubleshooting and Service

There are no user-serviceable parts on these modules. For troubleshooting, refer to the LED descriptions earlier in this guide. If the LEDs are not lit at all, there may be no power applied. Also, ensure the switches are set correctly.

If you are unable to establish communications from the host controller PC to the chassis, check the following.

- Ensure the appropriate chassis drivers and system module driver are installed on the host controller PC
- A faulty PCIe System Module or Cable Interface card is not plugged into the chassis
- A faulty PCIe cable
- A failure of the chassis power supply

NOTE

A driver is required for the M9022A, M9023A and M9024A modules. Refer to the Keysight PXIe System Modules and Cable Interface Installation Guide for driver installation information.

NOTE

The most current version of Keysight IO Libraries is required prior to installing and running any other software. The latest version can be downloaded from: www.keysight.com/find/iosuite.

NOTE

The additional ports on the M9024A operate like IO ports on the connected PC. For multiple chassis systems with an M9037A Embedded Controller, a single M9024A may be installed in one of the slave chassis.

If power is applied and the switches are set correctly, and either the LEDs are not lit or are lit incorrectly, the module may be defective.

Replacement part numbers are as follows:

Module	Replacement Part Number
M9048A	M9048-66101
M9048B	M9048-66102
M9049A	M9049-66101



This information is subject to change
without notice
© Keysight Technologies, Inc. 2015
Edition 1 June 2015
Published in USA



M9049-90001
www.keysight.com